

VULCAN X

Vehicle Mount Computer

Selling Features

2020/9/11 V.1



Always on rugged

01

Introduction

02

Outlook

03

Features Highlight

04

Applications



VULCAN X 10.4"

Target Segment



Agriculture



Cold Chain Logistics



Waste management trucks



Warehouse forklift



Mining Truck



Port cranes

System

- Intel Core i5-8365UE 1.6GHz
Intel Celeron 4305UE 2GHz (optional)
- 4GB DDR4 SODIMM, expandable to 32GB
- M.2 2280 SSD
- Built-in 6-axis motion sensor, built-in 2 speakers

Display

- 10.4" XGA TFT LCD with LED backlight (1024 x 768)
- 1200 nits brightness supports auto-dimming
- 5-wire resistive touch supports defrost/ defog function
- PCT touchscreen supports glove and rain mode (by request)

Communication

- Wi-Fi 802.11 a/b/g/n/ac/v/r/k
- Bluetooth V5.0
- Optional 4G LTE / HSPA+ / GPRS or 5G
- Optional GNSS (GPS/Galileo/GLONASS/BeiDou/QZSS)

Function Button

- Programmable button x 7, brightness adjustment x 2, volume adjustment x 2, display on/off x 1
- Optional defrost/ defog button x 1

I/O Interface

- RS-232 with power supported x 1
- RS-232(TX,RX)/422/485 x 1, RS-232(TX,RX) x 2, RS-485 x 2
- Gigabit Ethernet x 2
- USB 3.1 x 1, USB 2.0 x2, USB 3.1 type C x 1 (DP Alt Mode supported)
- Micro SD slot x 1, Micro SIM slot x 2
- Optional CAN bus 2.0B x 2 or SAE J1939 x 1
- DI x 2, DO x 2
- Mic in x 2, Line out (L/R) x 1
- Optional video input

Power Management

- 9~60 VDC input
- Ignition sense with delay on/off setting
- Wake on RTC
- Internal backup battery for graceful shutdown

Durability

- IP66, MIL-STD-810H, IEC 60721-3-5 class 5M3
- Operating temperature : -30°C to 55°C

Dimensions & Weight

- 276 x 234 x 57 (mm)



Outlook

ID Diagram & Dimensions

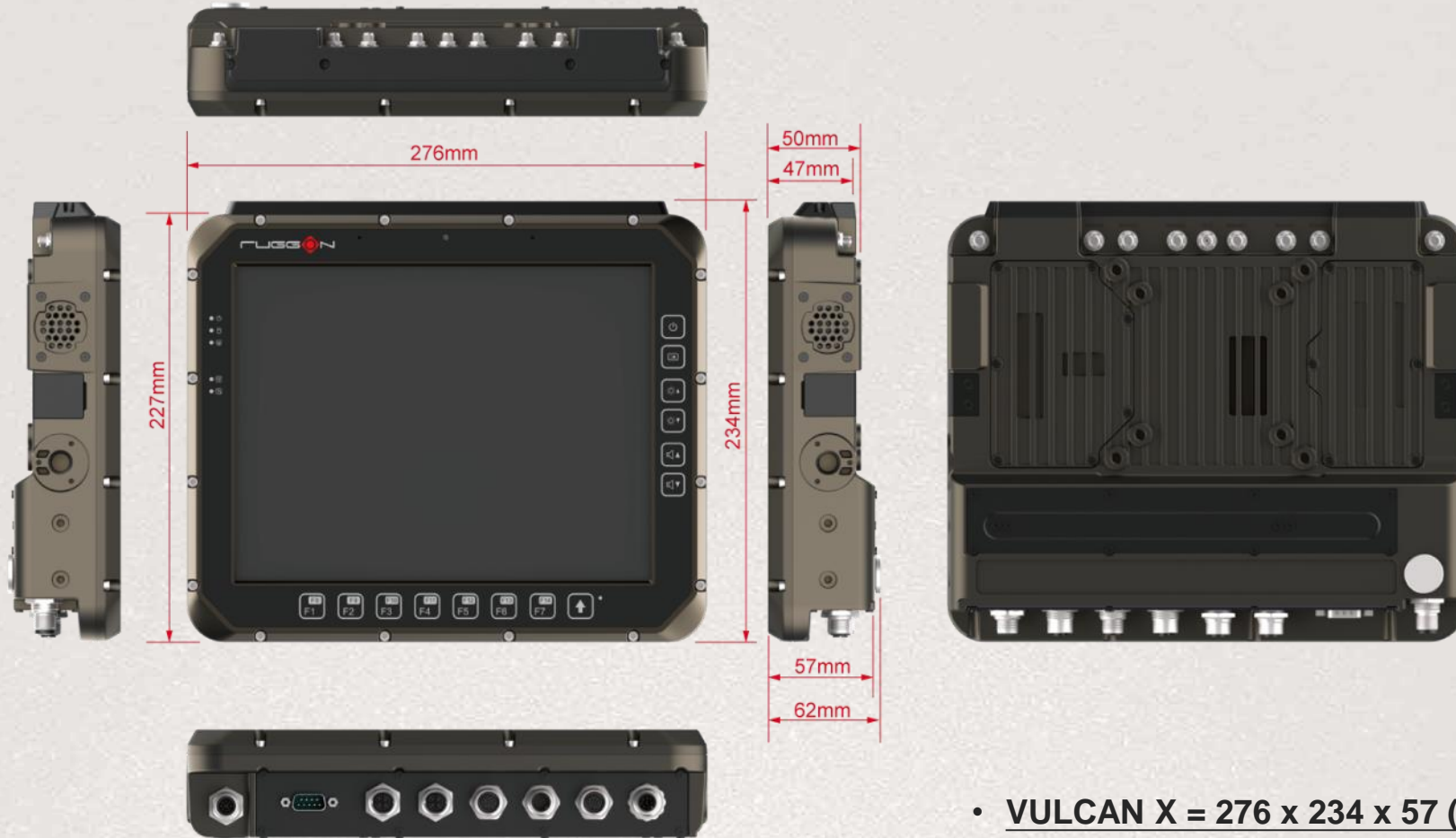

- VULCAN X = 276 x 234 x 57 (mm); 3.2 kg

Front View

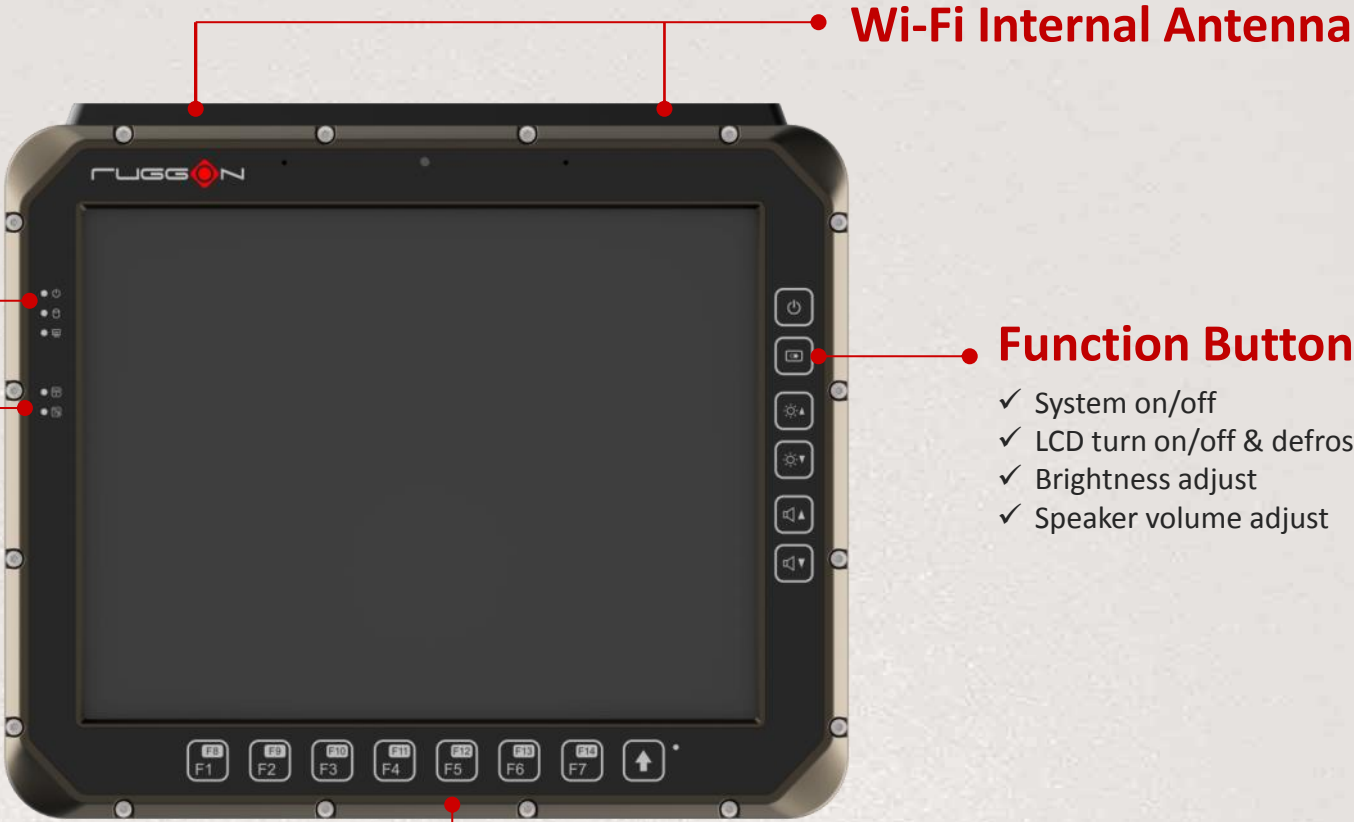

System LED Indicators

- ✓ System status
- ✓ Storage status
- ✓ Defrost status

Communication LED Indicators

- ✓ WWAN enable
- ✓ Wi-F/BT enable

Wi-Fi Internal Antenna

Function Button

- ✓ System on/off
- ✓ LCD turn on/off & defrost on/off
- ✓ Brightness adjust
- ✓ Speaker volume adjust

Friendly Programmable Keys

- ✓ You can configure the programmable buttons via DashON to different commands or keyboard shortcuts to better fit your work style

Rear View

Service Door

- ✓ Storage : M.2 SSD
- ✓ Expansion :
 - 1 x M.2 for WWAN card
 - 1 x M.2 for Wi-Fi/BT card

Standard Mounting Cable Position Fixed

- ✓ VESA 75 / 100 support
- ✓ Easy for mounting installation

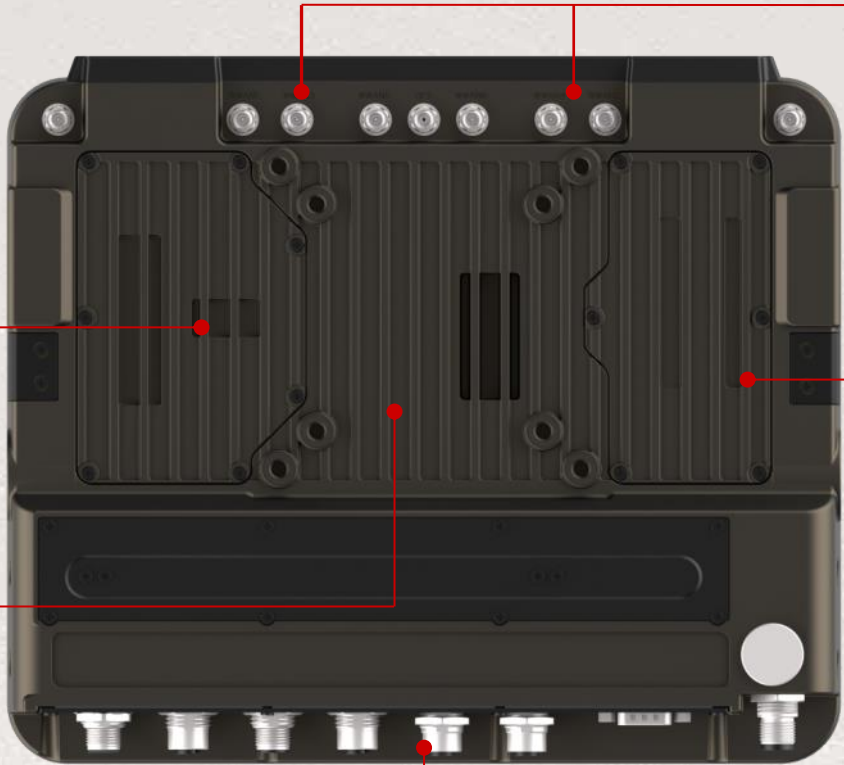

External Antenna Expansion

- ✓ SMA type: WLAN / WWAN/ GNSS

Service Door

- ✓ Memory : DDR4 SO-DIMM slot

Waterproof I/O Module

I/O Interfaces

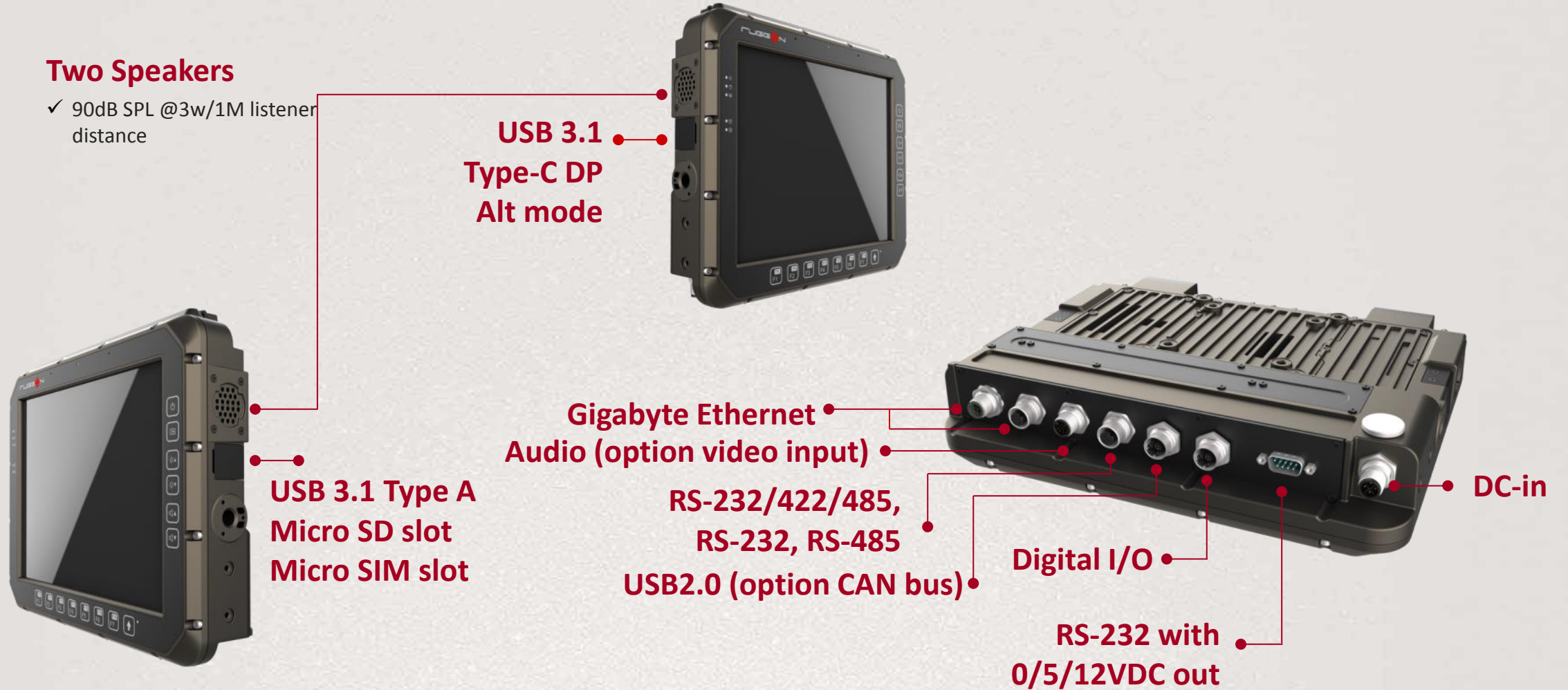



Feature Highlight

Robust Construction

- ◆ **All-around IP66 protection: : IEC 60529**
- ◆ **A wide operating temperature range from -30°C to 55°C**
- ◆ **Shock and Vibration Resistance**
 - ◆ **MIL-STD-810H 514.8 procedure**
 - ◆ US highway trucks (Figure 514.8C-2 Category 4)
 - ◆ composite two-wheeled trailers (Figure 514.8C-4 Category 4)
 - ◆ composite wheeled vehicles (Figure 514.8C-6 Category 4)
 - ◆ **MIL-STD-810H 516.8 procedure**
 - ◆ Operating: Procedure 1 Functional Shock
 - ◆ Non-Operating: Procedure V Crash Hazard Shock
 - ◆ **IEC 60721-3-5 Class 5M3**

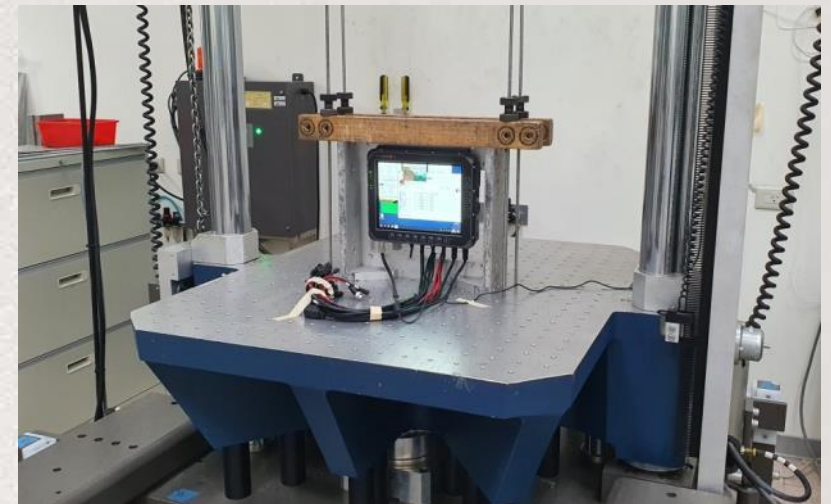

Robust Construction

Always on rugged

- ◆ **Salt fog corrosion resistance**

- ◆ Featuring corrosion resistant coatings and screws
- ◆ Salt fog testing is performed in accordance with MIL-STD-810H METHOD 509.7 SALT FOG

- ◆ **Metal and secured connectors**

- ◆ Against oil contamination, UV, vibrations, shocks, and expanded temperature range
- ◆ Secured M12 connectors for serial, digital I/O, USB and Ethernet
- ◆ M12 connectors with different coding to avoid mis-plug in the cable



Superb Visibility



The high brightness (1200 nits) display with auto-dimming feature enhances the visibility in any ambient light conditions



Defroster Function

With optional screen defog and defroster, the applications can be extended from outdoor to cold storage environments.



Press defog/ defroster button



Reserve an expansion module and antennas for 5G



- ◆ Ultra-reliable low latency communications
- ◆ Enhanced mobile broadband
- ◆ Advantages in monitoring, tracking and smart surveillance applications

SMA antenna connectors



High Performance WiFi Network

- ◆ Dual-band Support with IEEE 802.11 a/b/g/n/ac
- ◆ Fast roaming support (802.11k/v/r)

VULCAN X can stay seamlessly connected throughout the network coverage area and roam smoothly among the Aps.

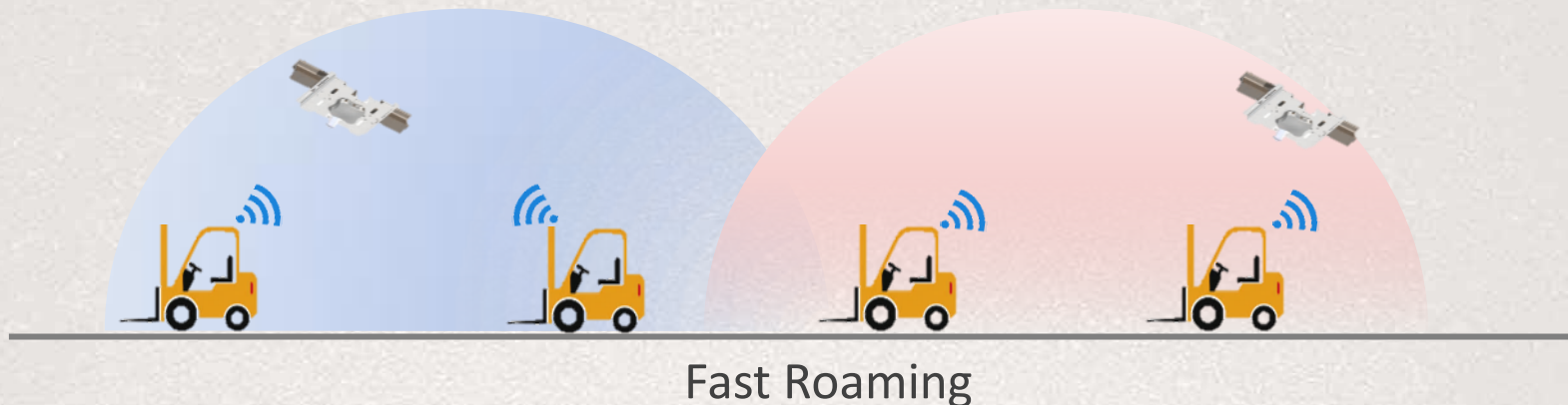

Smart Power Management

- ◆ Vehicle-grade power protection against sudden surges, noise filtering, overvoltage/ lower voltage and overcurrent protection

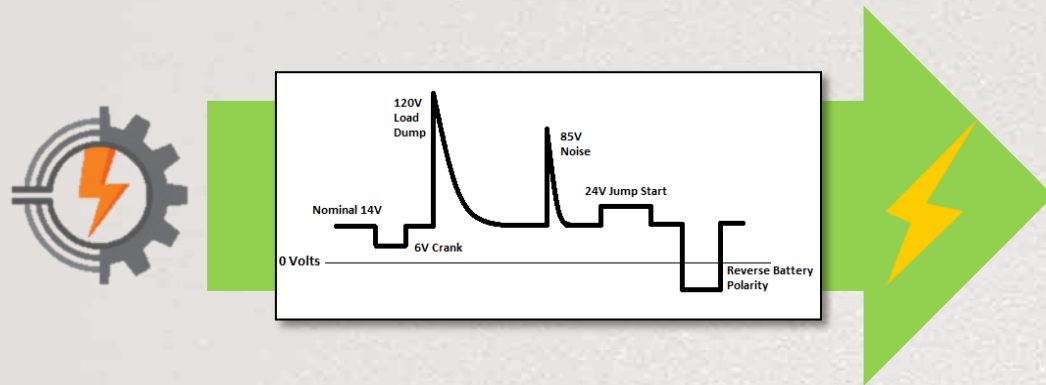

- ◆ 9 ~ 60 VDC wide range power input

- ◆ Ignition sense and delay on/off setting support
- ◆ A backup battery for safe shutdown and data saving while the sudden power loss



Second Display Available

- ◆ Easy to connect second display by a simple one cable : USB Type-C DisplayPort Alt Mode
- ◆ Support two display mode – extended mode or clone mode

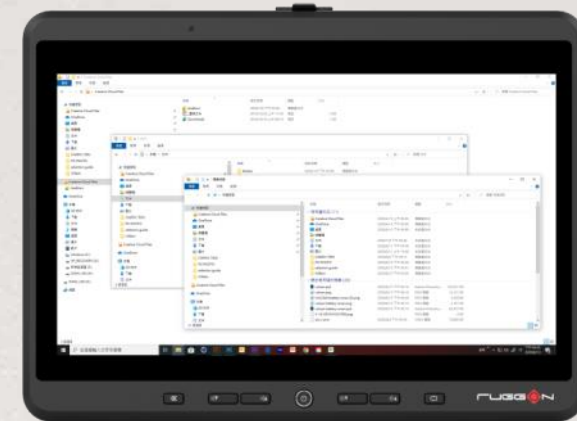

Extended mode

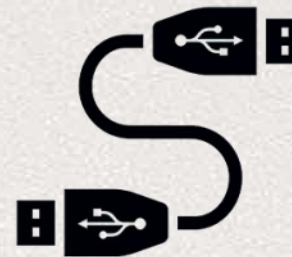

Clone mode

Flexible I/O Orientation

The varied I/O orientation design reserved to match different application scenarios.

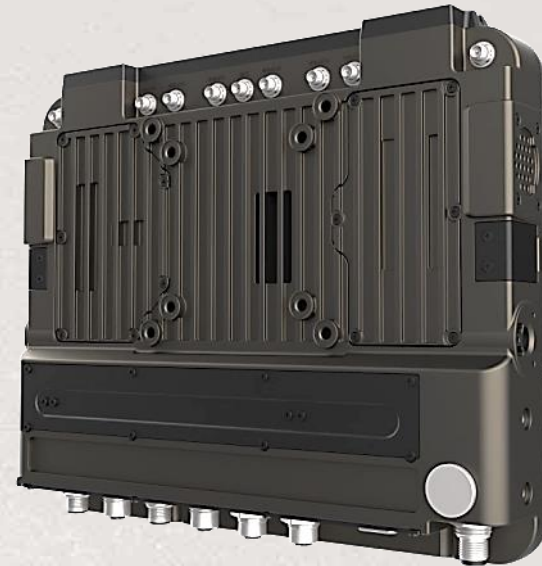

Tailored Accessories

Always on rugged



Antenna



Inline Fuse Holder



Power Cable

Antenna & Power Cable



Mounting Kit



U-shaped Bracket



Mount kit for keyboard



Holder kit for Barcode

Mounting Kit



Applications

Warehouse Management

Always on rugged

Application :

Forklift for outdoor/ cold storage

Requirement :

- ✓ Anti-Vibration/Shock
- ✓ 24/48V wide range power input
- ✓ Bluetooth to connect the barcode scanner
- ✓ Wi-Fi fast roaming for real-time warehouse management
- ✓ Defrost/ defog for cold chain



Application :

Container handling forklift and material handlers

Requirement :

- ✓ Anti-Vibration/Shock
- ✓ IP66 grade waterproof for outdoor
- ✓ Anti-salt fog corrosion resistance
- ✓ Wi-Fi for real-time terminal management
- ✓ 4G/ 5G...



Waste Management

Application :

Garbage pick-up, route management, monitoring

Requirement :

- ✓ GPS for route management
- ✓ WWAN network to cloud database
- ✓ Backup battery
- ✓ Rich I/O for RFID/ Weight scaler/ Printer
- ✓ Rear side, lateral side camera for safety and behavior record

